

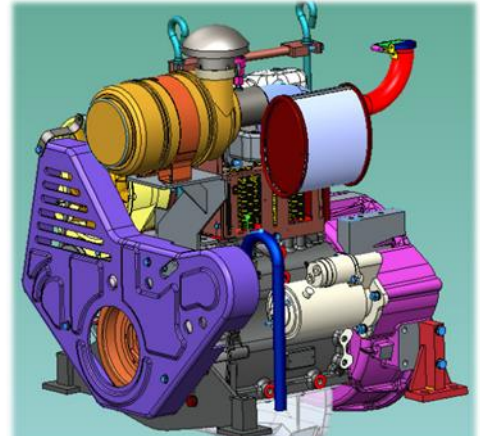

# HA394 - KIRLOSKAR Air cooled engines for Generating Sets

## Key Features

- Designed for heavy duty applications
- Extremely reliable.
- Lower operating cost.
- Easy maintenance – higher uptime.
- All service points like dipstick, lube oil filling, lube oil filter, fuel pump, injectors are on one side which is the cooler side. This adds to operator comfort.
- Ideally suitable for Telecom, Services, Residential application etc.
- Superior design standards that minimize power deration even at high ambient temperatures.



This image is shown for illustration purpose actual product may be different

Engine Specifications			
Engine Make	Kirloskar	Direction of Rotation	CCW from flywheel end
Engine Model	HA394	Gross Prime Power KW (hp) at 1800 rpm as per ISO 3046	27.97 (38)
Number of Cylinders	3	Fuel consumption at 100%load (lit/hr)	7.3
Configuration	Inline	Fuel consumption at 75%load (lit/hr)	5.8
Type	Four stroke	Fuel consumption readings are based on diesel fuel with a specific gravity of 0.85 and conforming to BS 2869, Class A2 with +5% tolerance)	
Bore x Stroke (mm)	100 x 120	Lube Oil Used	SAE 15W40, API C14
Displacement (cc)	2820	Lube Oil Sump Capacity (lit)	9.0
Cooling	Air cooled	Starting Method	Electric (12V)
Aspiration	Naturally Aspirated	Dimensions in mm (L x W x H)	808 x 704 x 873
Compression Ratio	18 : 1	Net Weight in kg (dry)	340





Enriching Lives

## KIRLOSKAR OIL ENGINES LIMITED

A Kirloskar Group Company

Head Office: Laxmanrao Kirloskar Road, Khadki, Pune 411 003, India.

Tel.: +91 20 2581 0341 / 534 Fax: +91 20 2581 3208 Website: [www.koel.co.in](http://www.koel.co.in)

### International business office:

#### KIRLOSKAR DMCC

JBC-5, Cluster W, Jumeirah Lake Towers, P. O .Box 37745, Dubai. U.A.E

Tel.: +971 4 443 8591

Fax: +971 4 441 4532

Email: [enquiry@kirloskar.ae](mailto:enquiry@kirloskar.ae)

Website: [www.kirloskarib.com](http://www.kirloskarib.com)

#### KIRLOSKAR TRADING SA(PTY) LTD

Unit B1, The Stables Business Park, Cnr of Third Avenue & Second Road, Limbro Park, Modderfontein, Johannesburg.

Tel.: +27(0) 11 553 6900/6903

Email: [kirsons@kirloskar.co.za](mailto:kirsons@kirloskar.co.za)

#### KIRLOSKAR KENYA LTD.

P.O. Box 60061, Off Dunga Road, Nairobi, Kenya. Tel.: +254 20 653 6632

Fax: +254 20 653 3390

Email: [Raj.Patil@kirloskar.com](mailto:Raj.Patil@kirloskar.com)

#### KIRLOSKAR AMERICAS CORPORATION

33300 Egypt Lane, Suite C300, Magnolia, TEXAS – 77354, United States

Tel.: +1 346 248 5777

Email: [Vinay.Kulkarni@koelamerica.com](mailto:Vinay.Kulkarni@koelamerica.com)

#### THE REP. OFFICE OF KIRLOSKAR

Suite 1331A, 13th Floor, Level One Saigon, mPlaza Saigon,

No. 39 Le Duan Street, Ben Nghe Ward, District 1, Ho Chi Minh City,

Vietnam Tel.: +84 77 9659756

Email: [Sanjay.Kunchetti@kirloskar.com](mailto:Sanjay.Kunchetti@kirloskar.com)

Kirloskar Oil Engines Limited reserved the right to change the design or specifications without notice.

---

IBG.T.192 Rev 1

Power, Performance, Peace of Mind.

