



Enriching Lives

KIRLOSKAR DIESEL ENGINES

Engine Model : DV8

No. of Cyls.	Bore x Stroke (mm)	Displacement (cc)	Gross Power Output Rating as per ISO3046 at 1800 RPM bhp (kW)		Suitable Power Rating for Generator at 0.8 pf	
			Prime	Standby (ESP)	Prime	Standby (ESP)
8	130 x 150	15910	490 bhp (360.6 kW)	539 bhp (396 kW)	400 kVA	440 kVA

Features -

- Designed for heavy duty applications
- Extremely reliable
- Lower operating cost
- Easy maintenance – higher uptime
- Superior design standards that minimize power deration even at high ambient temperatures.
- Winner of the frost & Sullivan Voice of Customer Award in the “Best Bang for Buck” category in the Indian Generating sets Market.

Ratings Definition:

Standby Ratings: These ratings are applicable for supplying continuous electrical power (at variable load) in the event of a utility power failure. No overload is permitted on these ratings. The alternator on this model is peak continuous rated (as defined in ISO 8528-3)

Prime Rating: These ratings are applicable for supplying continuous electrical power (at variable load) in lieu of commercial purchased power. There is no limitation to the annual hours of operation and this model can supply 10% overload power for 1 hour in 12 hours.

Continuous Rating: These ratings are applicable for supplying power continuously to a constant load upto the full output rating for unlimited hours. No sustained overload capability is available for this rating.

Power, Performance, Peace of Mind.

KIRLOSKAR



Enriching Lives

Engine Technical Data :

Physical Data	
Engine Make	Kirloskar
Engine Model	DV8
Number of cylinders	8
Configuration	V-type
Type	Four stroke
Bore x Stroke (mm)	130 x 150
Displacement (cc)	15910
Cooling	Liquid cooled
Aspiration	Turbocharged After cooled
Compression Ratio	16.5 : 1
Starting Arrangement	24V Electric

Fuel System				
Type of fuel filter	Spin on type			
Governor Type	Electronic			
Class of Governing	ISO 3046 Class A0 & ISO 8528 G2			
Fuel pump type	Inline			
Fuel pump make	Kirloskar			
Recommended Fuel	Class A2, High speed diesel			
Fuel consumption at +5% tolerance	Load	100%	75%	50%
	L/hr	84.9	63.2	46.0
Fuel consumption readings are based on diesel fuel with a specific gravity of 0.85 and confirming to BS 2869, Class A2)				

Air System	
Air Filter Type	Dry type replaceable element
Exhaust gas flow rate (kg / hr)	1789
Combustion fresh air flow (m ³ /hr)	1980
Radiator air flow (m ³ /hr)	36000
Total fresh air required (m ³ /hr)	37980

Lubrication System	
Type of lube oil filter	Full flow spin on type
Oil to be used	SAE 15W40 API : CI4
Oil pump type	Through G-rotor gear pump
Lub oil sump capacity (lit)	41
Lube oil consumption	0.12% of fuel consumption

Cooling System	
Cooling system capacity (lit)	123
Water pump type	Centrifugal
Radiator fan load (hp)	13.6

Electrical System	
Starting Arrangement	24V Electric
Starter	24V Electric
Recommended starter battery rating	2 x 210 Amp-hr
Battery charging alternator	Engine mounted 24V battery charger
Battery charger amps	45

Power, Performance, Peace of Mind.



Enriching Lives

Engine Dimensional Details :

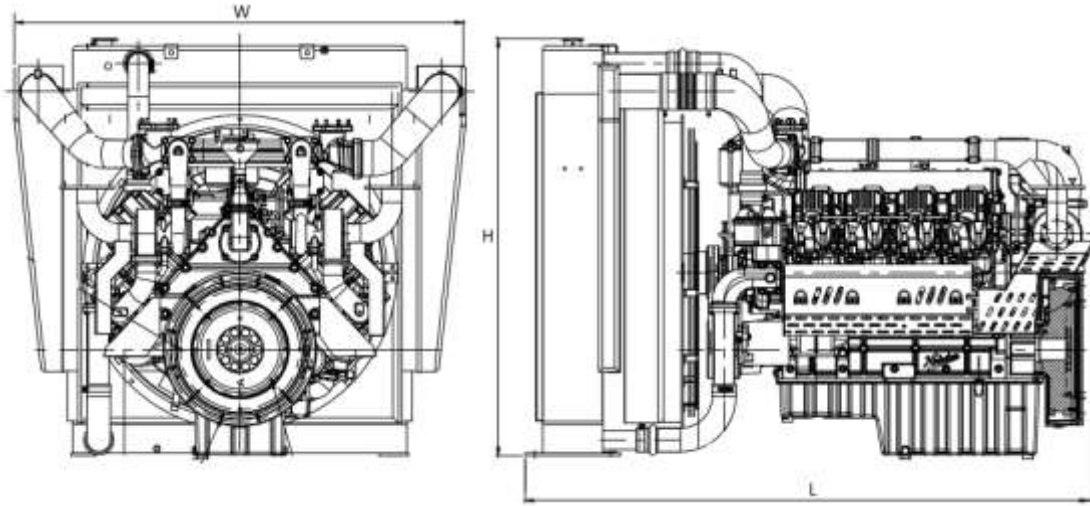

Dimensions in mm					
L	W	H	C	X	Y
2056	1624	1547	Please refer to engine GA drawing		
Weight Details			Coupling		
Engine weight without radiator Gross / Net (kg)		2030 / 1920	Flywheel	Suitable for SAE 14" disc	
Radiator and accessories weight Gross / Net (kg)		690 / 570	Housing	SAE1	
			Coupling disc	Not supplied	

(* Please refer to the respective rating GA drawing)



Enriching Lives

KIRLOSKAR OIL ENGINES LIMITED

Head Office: Laxmanrao Kirloskar Road, Khadki, Pune 411 003, India.

Tel.: +91 20 2581 0341 / 534 Fax: +91 20 2581 3208 Website : www.koel.co.in

International business offices

KIRLOSKAR DMCC

JBC-5, Cluster W, Jumeirah Lake Towers, P.O.Box 37745, Dubai. U.A.E

Tel.: +971 4 443 8591 Fax: +971 4 441 4532

Email: enquiry@kirloskar.ae Website : www.kirloskarib.com

JOBURG INDUSTRIAL TRADING S.A.(Pty) LTD.

Unit B1, The Stables Business Park, Cnr of Third Avenue & Second Road, Limbro Park, Modderfontein, Johannesburg.

Tel.: +27(0) 11 553 6900/6903 Email: kirsons@kirloskar.co.za

KIRLOSKAR KENYA LTD.

P.O. Box 60061, Off Dunga Road, Nairobi, Kenya. Tel.: +254 20 653 6632

Fax: +254 20 653 3390 Email: rspatil@kirloskar.co.ke

KOEL AMERICAS CORPORATION

33300 Egypt Lane, Suite C300, Magnolia, TEXAS – 77354, United States

Tel. : +1 346 248 5777 Email: Vinay.Kulkarni@koelamerica.com

VIETNAM REPRESENTATIVE OFFICE

Suite 1331A, 13th Floor, Level One Saigon, mPlaza Saigon,

No. 39 Le Duan Street, Ben Nghe Ward, District 1, Ho Chi Minh City,

Vietnam Tel.: +84 1 229659756 Email: Sanjay.Kunchetti@kirloskar.com

Kirloskar Oil Engines Limited reserved the right to change the design or specifications without notice.