



Enriching Lives

HA294 - KIRLOSKAR Air cooled engines for Generating Sets

Key Features

- Designed for heavy duty applications
- Extremely reliable.
- Lower operating cost.
- Easy maintenance – higher uptime.
- All service points like dipstick, lube oil filling, lube oil filter, fuel pump, injectors are on one side which is the cooler side. This adds to operator comfort.
- Ideally suitable for Telecom, Services, Residential application etc.
- Superior design standards that minimize power deration even at high ambient temperatures.

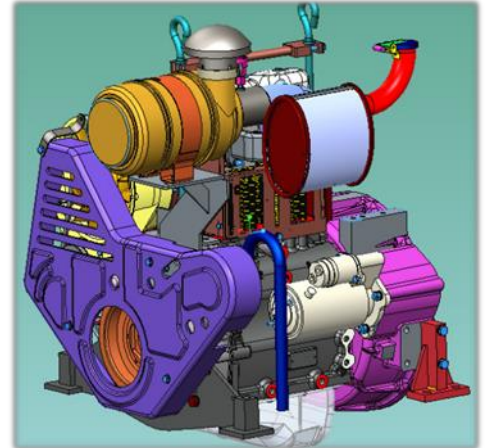

Engine Specifications			
Engine Make	Kirloskar	Direction of Rotation	CCW from flywheel end
Engine Model	HA294	Gross Prime Power KW (hp) at 1500 rpm as per ISO 3046	15.0 (20.5)
Number of Cylinders	2	Fuel consumption at 100%load (lit/hr)	3.90
Configuration	Inline	Fuel consumption at 75%load (lit/hr)	3.07
Type	Four stroke	Fuel consumption readings are based on diesel fuel with a specific gravity of 0.85 and confirming to BS 2869, Class A2 with +5% tolerance)	
Bore x Stroke (mm)	100 x 120	Lube Oil Used	SAE 15W40, API C14
Displacement (cc)	1885	Lube Oil Sump Capacity (lit)	5
Cooling	Air cooled	Starting Method	Electric (12V)
Aspiration	Naturally Aspirated	Dimensions in mm (L x W x H)	678 x 704 x 872
Compression Ratio	17 : 1	Net Weight in kg (dry)	285

KIRLOSKAR OIL ENGINES LIMITED

Head Office: Laxmanrao Kirloskar Road, Khadki, Pune 411 003, India.
Tel.: +91 20 2581 0341 / 534 Fax: +91 20 2581 3208 Website : www.koel.co.in



KIRLOSKAR DMCC

JBC-5, Cluster W, Jumeirah Lake Towers, P.O.Box 37745, Dubai. U.A.E
Tel.: +971 4 443 8591 Fax: +971 4 441 4532
Email: enquiry@kirloskar.ae Website : www.kirloskar.ae

Enriching Lives

Kirloskar Oil Engines Limited reserved the right to change the design or specifications without notice.
Contact your local distributor for more details.

